

DFE 146-S2 ErP

- Double inlet radial fan.
- High pressure, large air volumes and low sound levels.
- Impeller with forward curved blades.
- The external rotor motor has maintenance-free sealed ball-bearings.
- The motor is situated in the airstream to get ultimate cooling.
- Integrated motor protection.
- Can be ordered with junction box.
- For speed control a transformer or electronic speed controller can be connected.
- Fan housing is manufactured from galvanized sheet steel.
- Compact design for a minimum amount of space.
- Ideal for use in heat exchangers, dehumidifiers and air cleaners.

Accessories

- VRTE 3
- VRDE 3
- VRS 2.0

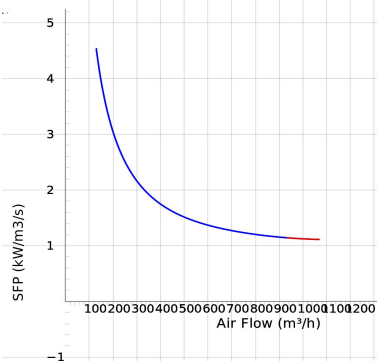
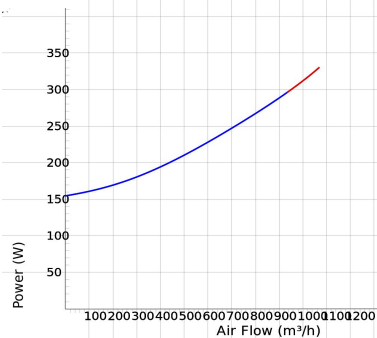
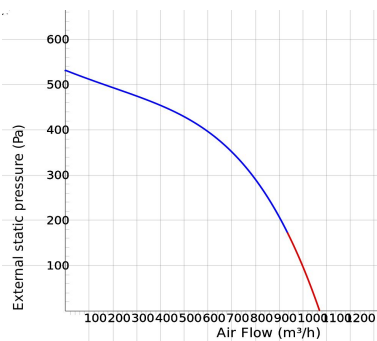

Voltage steps

1
230V

TECHNICAL DATA

7700228 DFE 146-S2 ErP outdrawn tp	
Voltage	230 V
Phase	1 ~
Frequency	50 Hz
Power	290 W
Current	1.3 A
Speed	1950 r.p.m.
Max. temperature of transported air	45 °C
Max. temperature of transported air when speed controlled	45 °C
Sound pressure level at 3 m	65 dB(A)
Weight	5.0 kg
Enclosure class	44 IP
Capacitor	12 µF
Max. flow	936.00262080734 m³/h
Max. pressure	541 Pa
Voltage range	220-240 V

SOUND DATA

	Flow (m³/h)	L_{WA} tot dB (A)	63Hz	125Hz	250Hz	500Hz	1KHz	2KHz	4KHz	8KHz
0. Surrounding L_w dB(A) 230V	814	73	46	53	64	66	66	67	64	58
0. Outlet L_w dB(A) 230V	641	77	57	64	62	65	72	72	70	66

DIMENSIONS

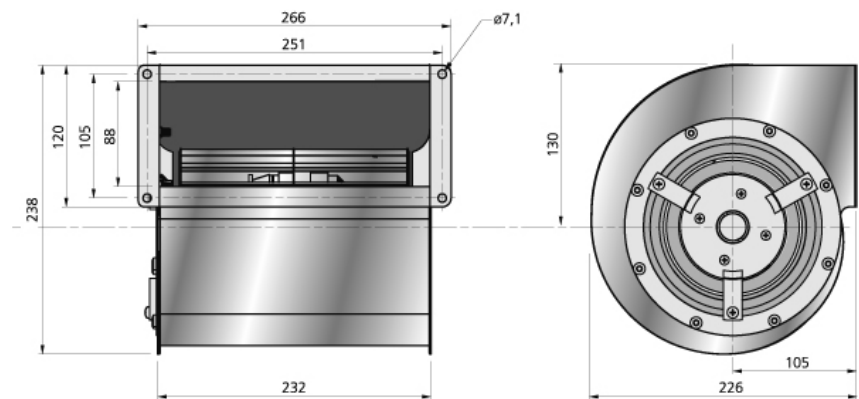

DISTRIBUTEUR EN TUNISIE

Rue de la Fonte, zone industrielle 2013 BEN AROUS
 Téléphone : 71 38 85 34 - Fax : 71 38 42 30
 E-mail : atv@atv.tn
 Site web : www.atv.tn